

SLIDE DOOR OPERATOR

MODELS SD & GSD

ADDENDUM

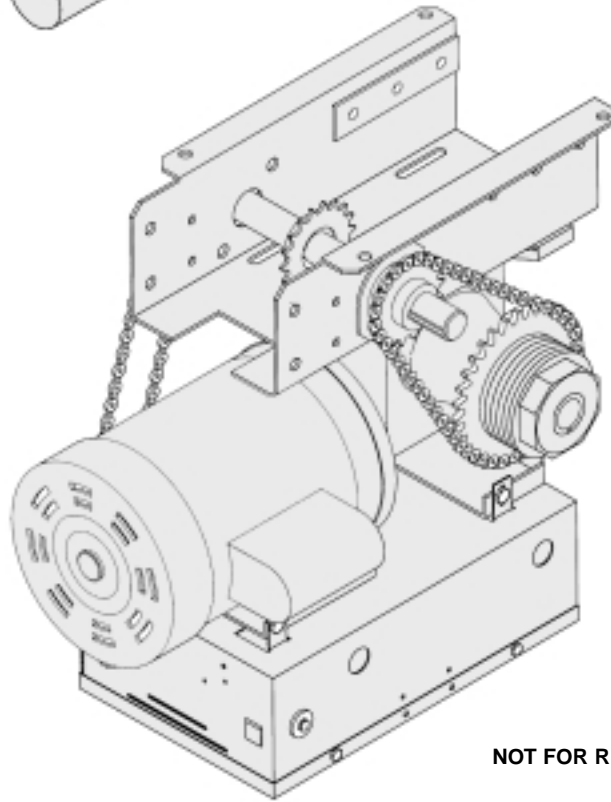
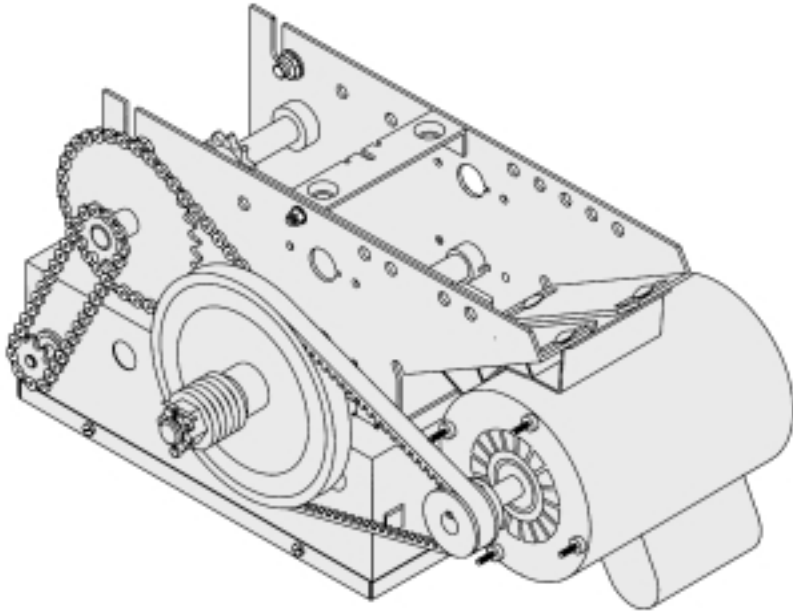

2 YEAR WARRANTY

Serial # _____
(located on electrical box cover)

Installation Date _____

Wiring Type _____

NOT FOR RESIDENTIAL USE



SPECIFICATIONS

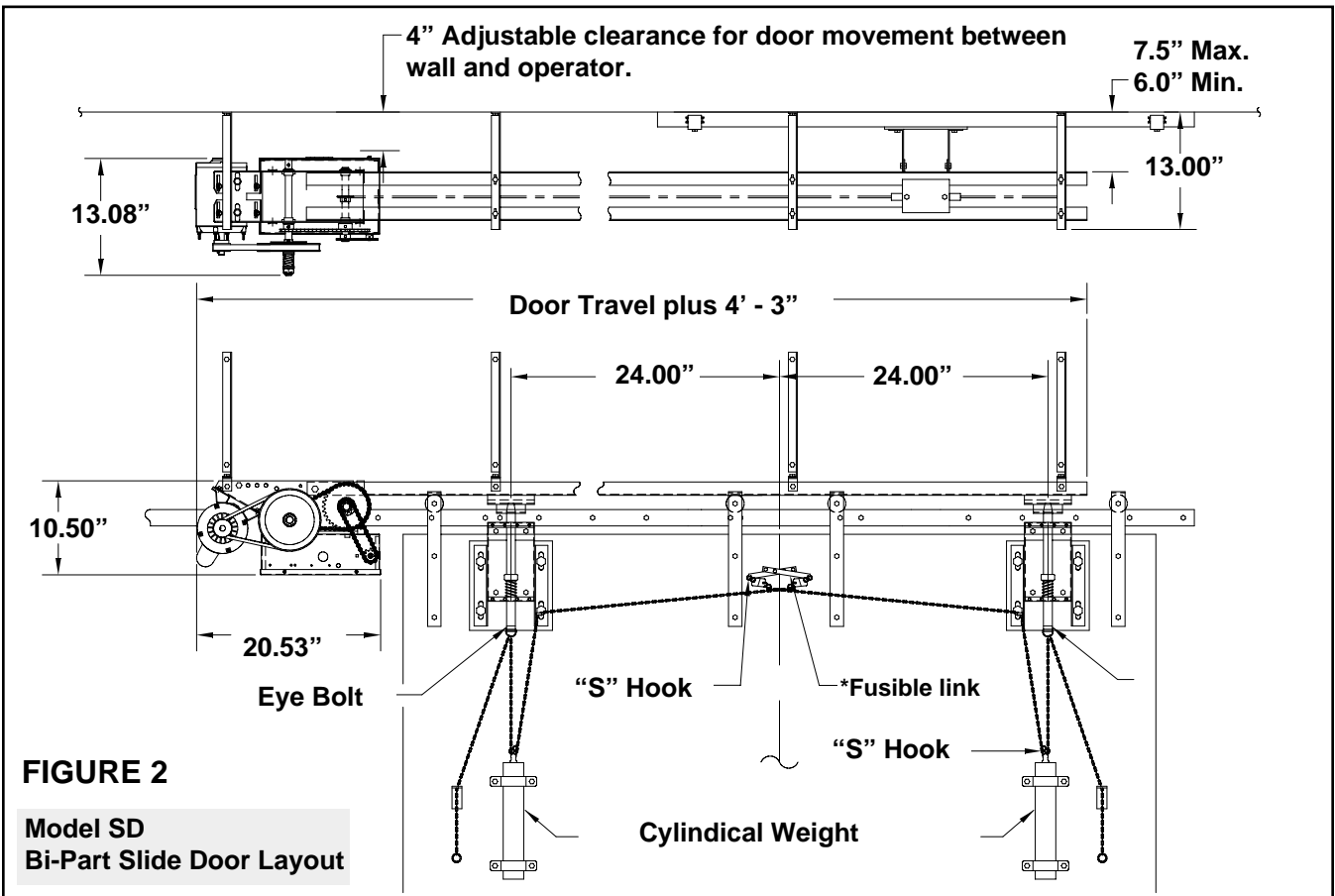
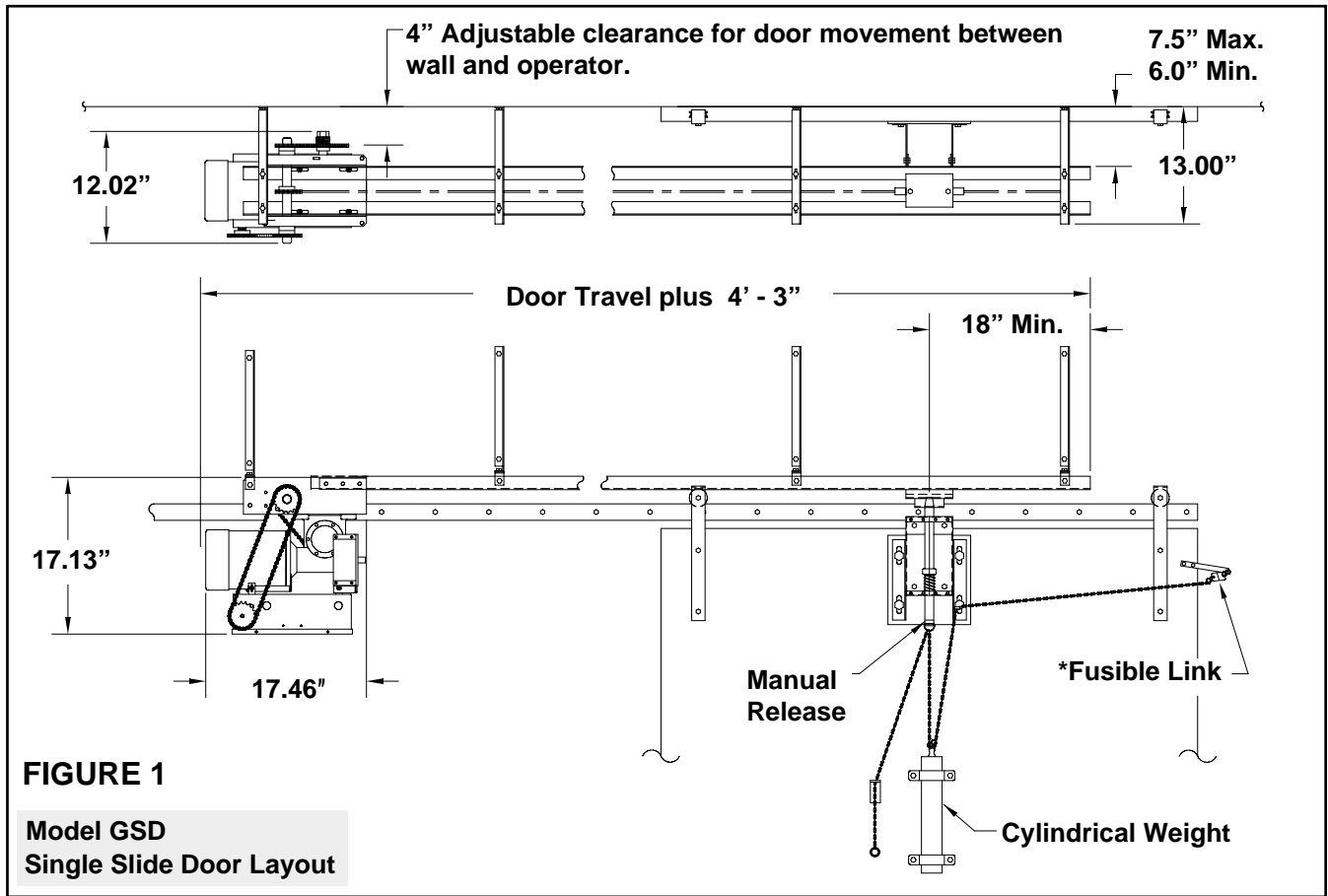

PREPARATION

1. Unpack carton, checking for possible damage during shipping. Damage claims must be filed with the freight carrier. Check that the nameplate data accurately specifies the operator that was ordered. Verify that the following parts listed below are included in the carton.

2. Check to make sure that the available power supply to be connected to the operator is of the same voltage, phase, frequency, and wattage as indicated on the nameplate of the operator.

3. In order for the door operator to function correctly, it is important that the door be properly aligned and working smoothly. Make any necessary corrections to the door to assure this before beginning operator installation. In addition, disconnect and remove all locking devices from the door to prevent damage or personal injury due to accidental locking.

IMPORTANT

This manual supplement includes only mechanical assembly instructions for your slide door operator. For complete list of operator features, specifications and wiring instructions, refer to the Owners Manual supplied with your operator.

HARDWARE KITS

- | KIT PART # | DESCRIPTION |
|-------------------|---|
| *K77-10473 | Complete Hardware Kit for Single Slide door |
| *K77-10474 | Complete Hardware Kit for Bi-Sliding doors |
| K75-10470 | Trolley Slider Kit for Single Slide door |
| K75-10471 | Trolley Slider Kit for Bi-Sliding doors |
| K75-10469 | Door Disconnect Kit |
| K75-16339 | Wall Bracket Kit |

PART #	DESCRIPTION	SINGLE SLIDE OPENING WIDTH						BI-PART SLIDE OPENING WIDTH			
		To 8'	10'	12'	14'	16'-20'	22'-24'	To 8'	8'-12'	12'-16'	16'-20'
See chart	Track	10-5808	10-5810	10-5812	10-5814	10-5820	10-5824	10-5812	10-5814	10-5820	10-5824
See chart	Roller Chain	19-5114	19-5114	19-5114	19-5114	19-5120	19-5124	19-5114	19-5116	19-5118	19-5120
K75-16339	Wall brackets	4	4	4	4	5	6	4	5	6	6

* (4) wall brackets are included in the standard hardware kit. Single doors over 14' or Bi-Part doors over 8' will require additional wall brackets, refer to chart.

OPERATOR ASSEMBLY

The slide door operator should be pre-assembled as follows before installation:

1. Layout the two pieces of track on the floor, parallel to each other and install end idler shaft assembly (see page 5).

2. Install track hanger brackets with 3/8" hardware (see page 5). The number of hangers will vary with the door width. The holes in the track for the hangers are pre-punched and are generally about 5 feet apart.

3. Install chain take-up bolt on slider carriage with two 3/8 hex nuts and lockwasher and slide the slider carriage onto the track so that the take-up bolt will be facing the powerhead (see page 5).

NOTE: For Bi-parting doors, slide secondary slider carriage into track assembly first, so that this slider is closest to the front idler.

4. Install one final track hanger on back of powerhead. Remove the spacer bar which comes assembled in the frame of the powerhead unit. Position the track assembly on the motor unit and reinstall the spacer within the rails, tightening the bolts securely. For a right to open single-sliding door, the powerhead should be mounted on the right hand end of the track with the pulleys facing out.

Install two 3/8-16 x 1" hex bolts with lockwashers and nuts through the remaining two mounting holes in the power head (see page 5).

5. Attach the chain to the take-up bolt on the slider carriage using the master link provided. Reel the chain around the drive sprocket, up to the idler shaft and then back to the hole on the front of the carriage.

6. Using the two 10-32 x 1-1/4 inch screws and hardware provided, attach the chain to the front end of the carriage (see figure 3). It may be necessary to remove some links for proper tension. Tighten chain by adjusting chain take-up bolt. A properly adjusted chain will sag about 3" at the midpoint.

NOTE: Leave Bi-part slider carriage free at this time.

7. Bolt the angle mounting brackets to the track hangers through the slots in the mounting brackets. Use the 3/8-16 hex head bolts with flatwashers under the heads and lockwashers and nuts under the track hangers (see page 5). Do not tighten as the distance from the wall to the track will have to be adjusted later.

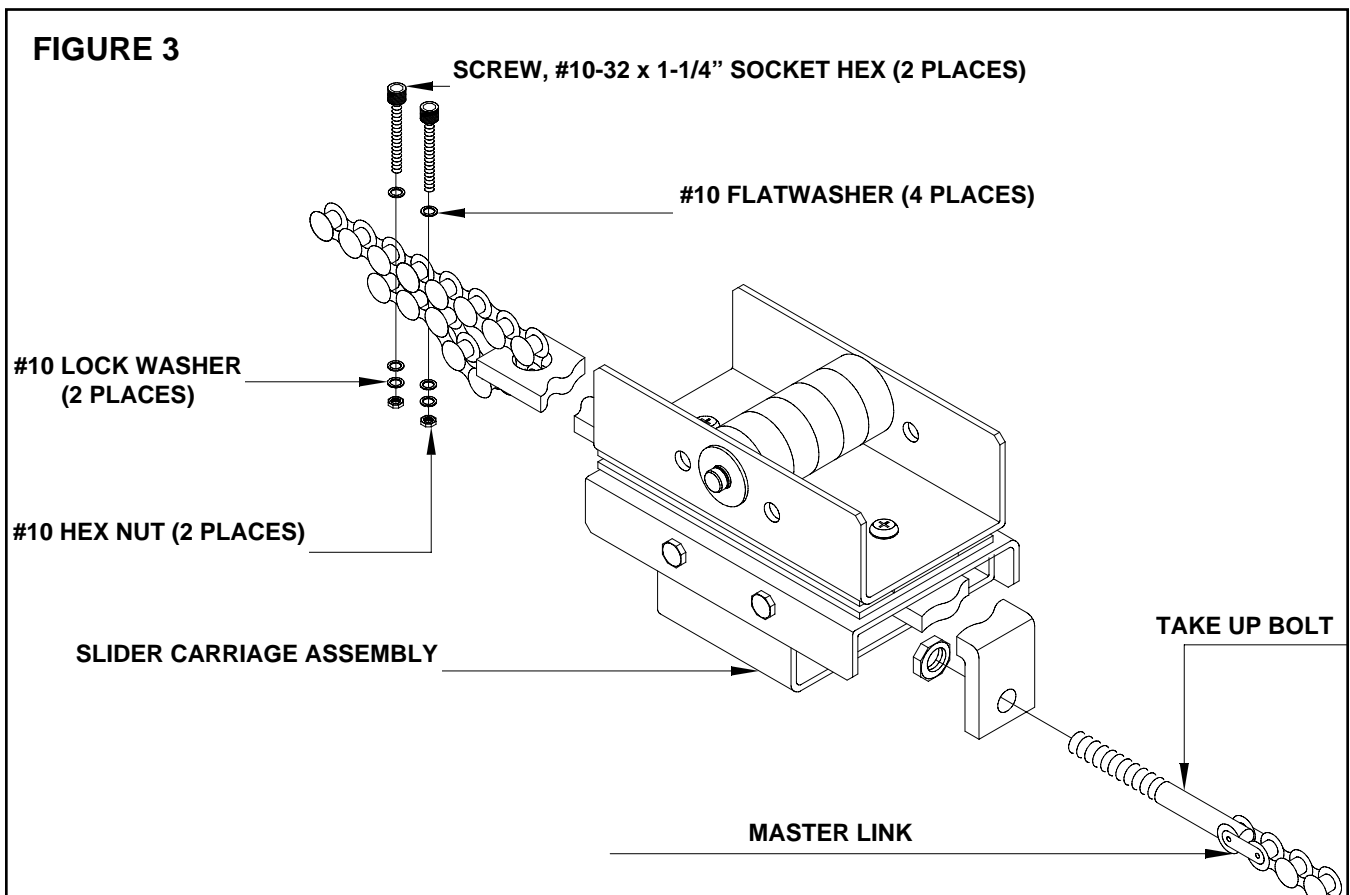

MOUNTING ASSEMBLY

FIGURE 4

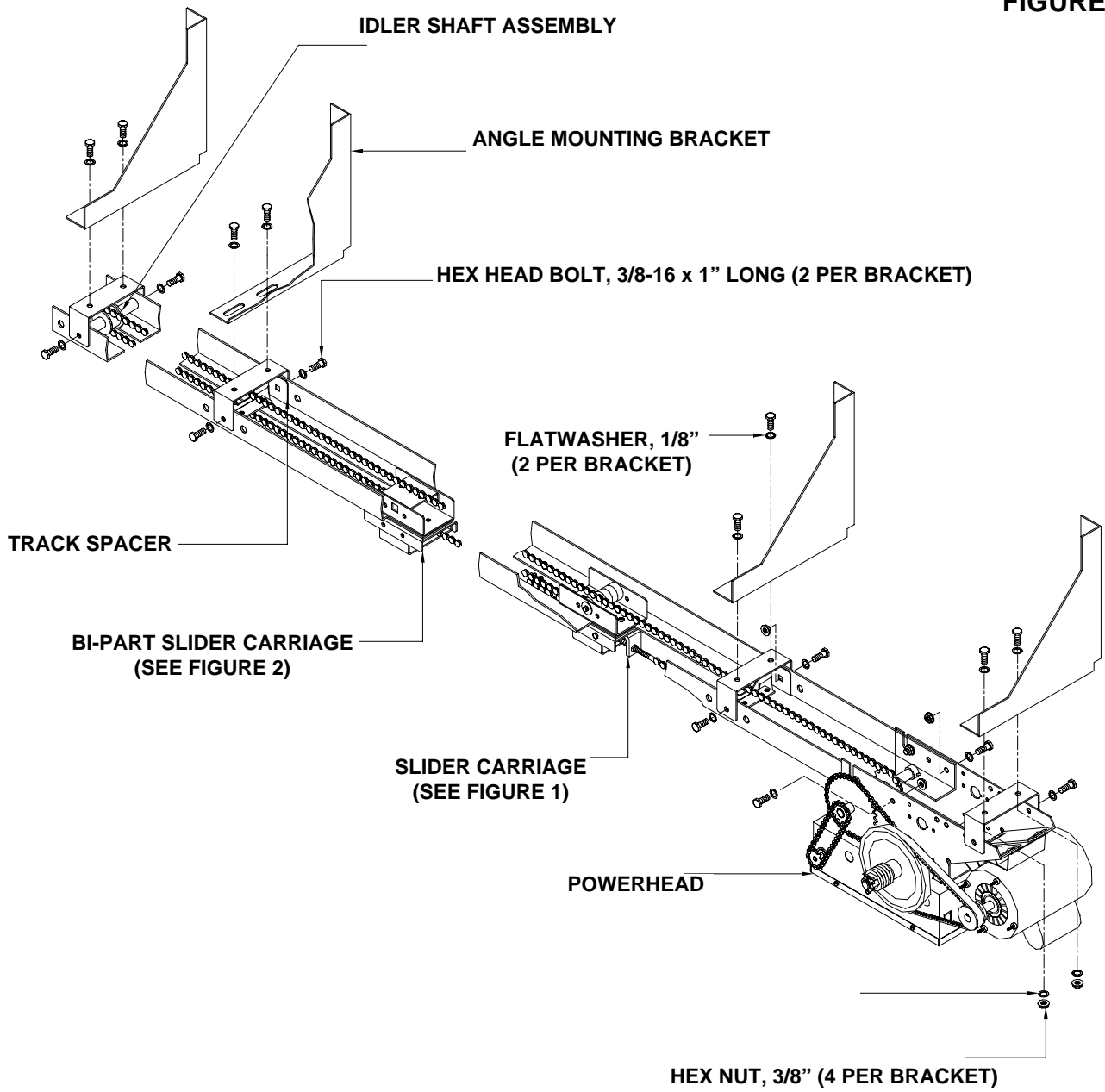

SERRATED FLANGE HEX NUT, #10

FIGURE 5

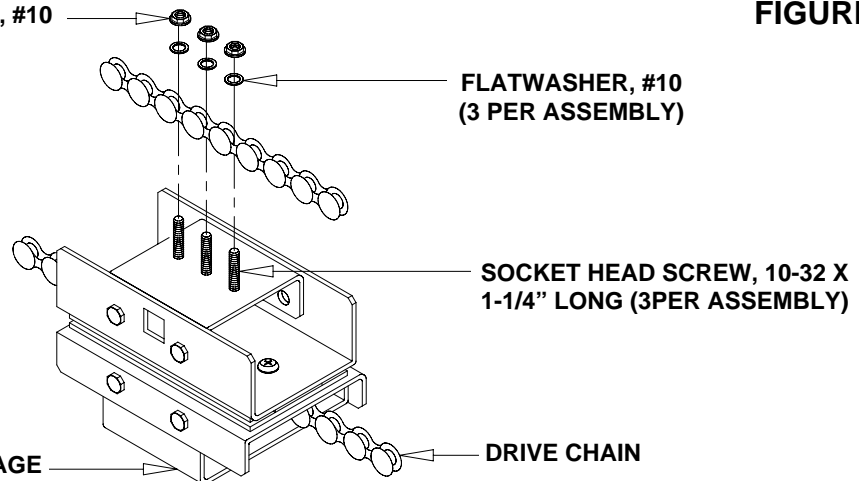

OPERATOR MOUNTING

NOTE: Refer the figures on page 2 for general information during this part of the installation.

1. Determine the clearance necessary for the door to pass between the powerhead and wall (see figure 6). This dimension must be less than 4 inches, it may be necessary to shim the brackets out from the wall accordingly.

2. With the door fully closed, locate the vertical center-line of the door and mark this line on the wall above the door. Measure 18" to the left of this line if the door slides left to close or 18" to the right of this line if the door slides right to close (see figure 1).

NOTE: For bi-parting doors, omit this step. The track should extend 3-1/2 feet beyond the door opening (see figure 2).

3. Set the assembled operator into position and mark the holes for the angle mounting brackets on the wall, as low as possible without interfering with door travel (see figure 6). Drill holes in the wall for mounting. Through-bolts are recommended for this purpose. If wall construction does not permit the use of through-bolts, lag bolts and shields may be used.

4. Secure the assembled operator to the wall.

IMPORTANT: BE SURE OPERATOR, TRACK AND DOOR TRACK ARE PARALLEL.

Check that the door clears the power head when moving. Adjust the track hangers on the mounting brackets to the desired position and tighten all bolts. It is recommended that at least one sway brace be used (not provided) between the wall and one of the track hangers for increased rigidity, especially on large or heavy doors.

5. Mount the door disconnect mechanism on the center-line of the door so that the top of the bracket is no more than 1-1/2" below the slider carriage (see figure 6). This mechanism may be adjusted both front to back and up and down to align the disconnect pin. It may be necessary to shim between the mechanism and the door to bring the pin out into the center-line of the track.

NOTE: For bi-parting doors, mount each door disconnect mechanism centered on a line 24" from the door edge (see figure 2).

6. Move the door so that the disconnect pin is directly aligned with the hole in the carriage and engage pin in hole.

FIGURE 6

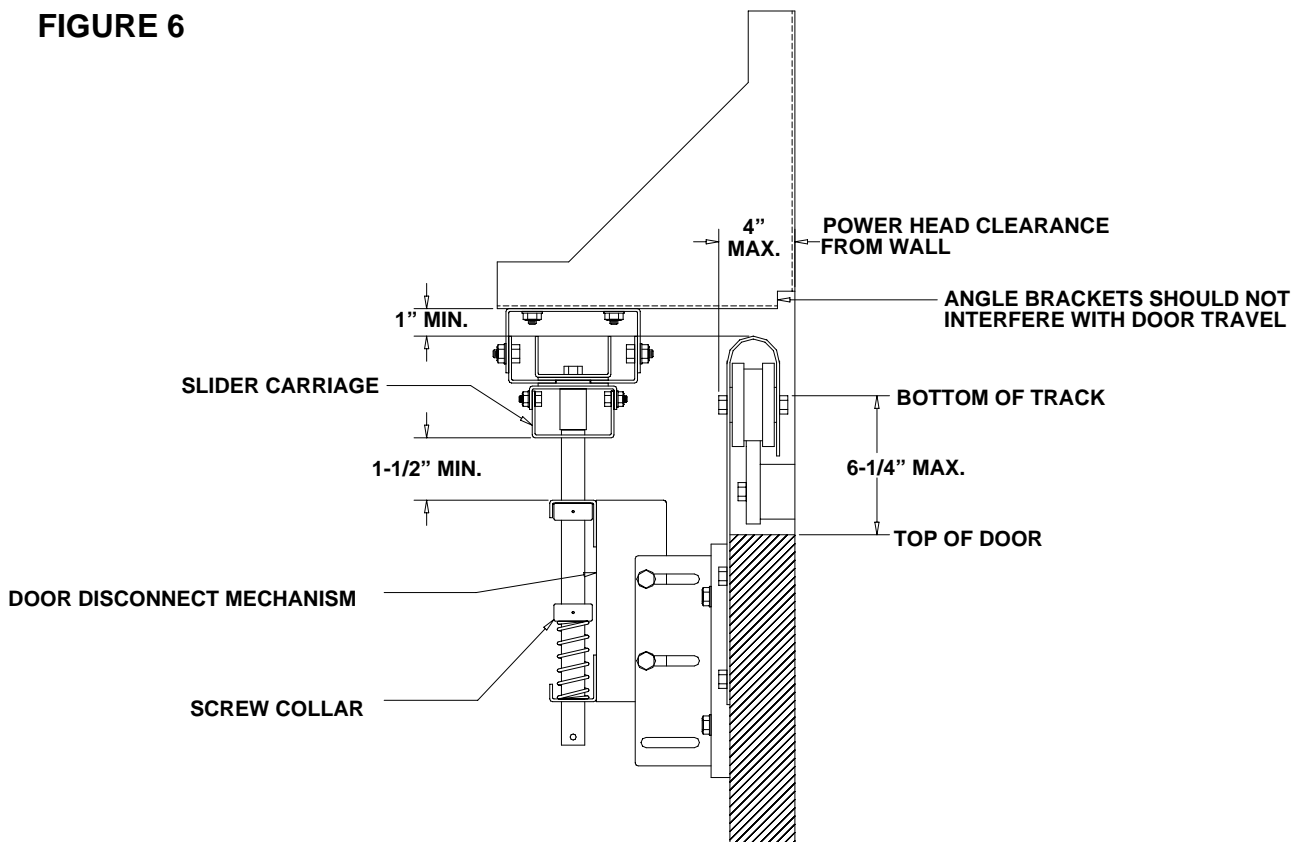

NOTE: For bi-parting doors, it is necessary to bring the doors to a fully closed position for proper synchronization. With both disconnect pins and engaged in their respective carriages, lift the drive chain over the three studs on the bi-part carriage and secure the chain to the slider with the hardware provided (see figure 5).

7. Adjust the screw collars on the disconnect pin so that it enters into the trolley bracket about 3/4".

8. Mount the chain retaining bracket (with keyhole slot) at a convenient height on the door, directly below and aligned with disconnect chain. Mount it so that keyhole is in the horizontal plane (repeat for bi-part door).

FUSIBLE LINK INSTALLATION (OPTIONAL)

1. Mount chain retaining bracket to door, approximately 4 ft. above the floor and 2 inches off centerline of door as shown in figure 1.

2. Attach eye bolt to lower slot on disconnect assembly (see figure 1).

3. Secure fusible link mounting bracket to upper leading edge of door (6 to 12 inches below top of door) so that the fusible link will be in door opening when door is open (see figure 1).

4. Thread the fusible link chain through the eye bolt as shown, then through the eyelet in the weight mechanism, and then up through the bottom of the disconnect pin.

5. Raise the weight to approximately 3 feet from floor level and engage the chain in the slot of the chain retaining bracket.

6. Couple the chain to itself around the weight so that the chain cannot move through the eyelet in the weight.

7. Disengage the chain and allow the weight to hang from the fusible link.

8. Leave a small amount of slack between the weight and the disconnect pin and fasten a split key ring to the link on each side of the disconnect pin so that the chain cannot pass through the hole.

9. Cut off excess chain, leaving 6" to hang below chain retaining bracket.

10. Fasten large split key ring to end of chain.

11. Mount the weight guide to the door as shown, with weight protruding above guide 3 to 4 inches.

12. For bi-part doors install the second fusible link assembly on the other door in the same manner. Be sure that one is lower than the other so as not to interfere with each other when the doors are fully closed.

13. **IMPORTANT:** TEST THE FUSIBLE LINK DISCONNECT INSTALLATION AS FOLLOWS: Manually remove the fusible link from the bracket and allow the weight to pull down on the disconnect pin. Verify that the door is disconnected and moves freely. If necessary, adjust spring on disconnect assembly by moving top shaft collar up or down.

ELECTRICAL CONNECTIONS & OPERATING INSTRUCTIONS

POWER AND CONTROL WIRING:

Refer to the Owners Manual supplied with your operator for all power and control wiring.

ELECTRICAL OPERATION:

The door can be operated by means of the three button control station or by other controls, when provided. Refer to Control Connection Diagram located on the back cover of the Owners Manual for all control options.

MANUAL OPERATION:

The door cannot be moved manually with the slider carriage connected. However, a quick disconnect pin and chain mechanism is provided to uncouple the door from the slider carriage. To disengage the door, simply pull the chain down and engage it in the keyhole slot on the bracket provided for this purpose. With the mechanism disconnected, the door can be manually opened or closed.

